

PARA EL MONTAJE DE HERRAMIENTAS CON TORNILLO DE BANCO CÓNICO.

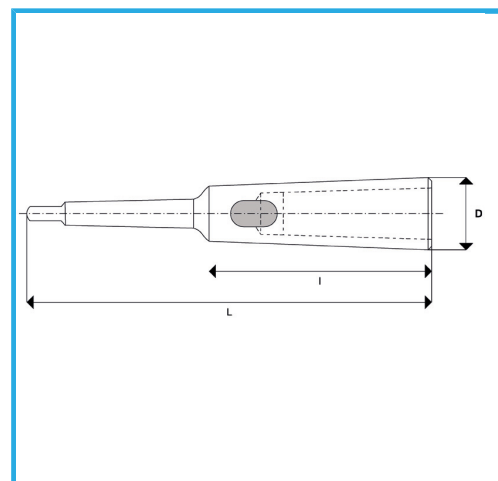

€23,80



CM Externo	2
CM Interior	2
L	175 mm
I	90 mm
D	30 mm
Peso bruto	0,51 kg
Codigo de barras	8012667349592



Caja



Templado



Acero



Rectificado