

ZUR AUFNAHME VON WERKZEUGEN SCHAFT.

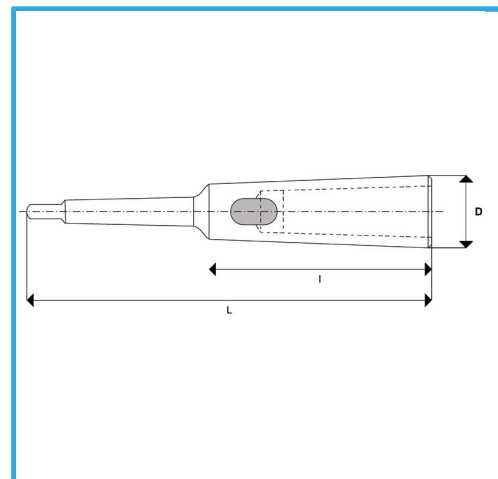

CM Extern	2
CM Intern	1
L	160 mm
I	85 mm
D	20 mm
Bruttogewicht	0,27 kg
EAN-Code	8012667349585



Box



Gehärteter



Stahl



Korrigiert



2187