

ZUR AUFNAHME VON WERKZEUGEN SCHAFT.

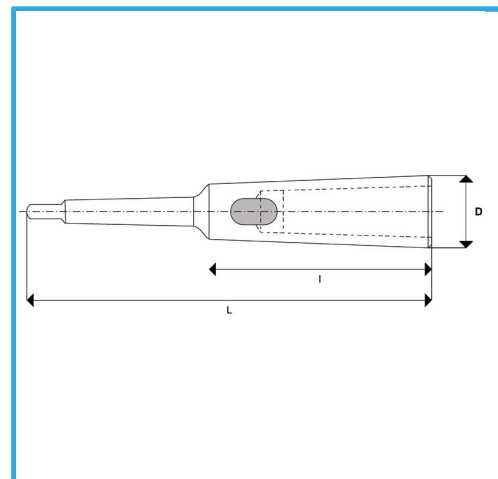

| | |
|---------------|---------------|
| CM Extern | 5 |
| CM Intern | 2 |
| L | 247 mm |
| I | 97,5 mm |
| D | 30 mm |
| Bruttogewicht | 1,92 kg |
| EAN-Code | 8012667349714 |



Box



Gehärteter



Stahl



Korrigiert