

GEEIGNET ZUR GEWINDEREGENERATION ODER UM SEHR WIDERSTANDSFÄHIGES GEWINDESCHNEIDEN IN WEICHE MATERIALIEN ZU ERHALTEN.

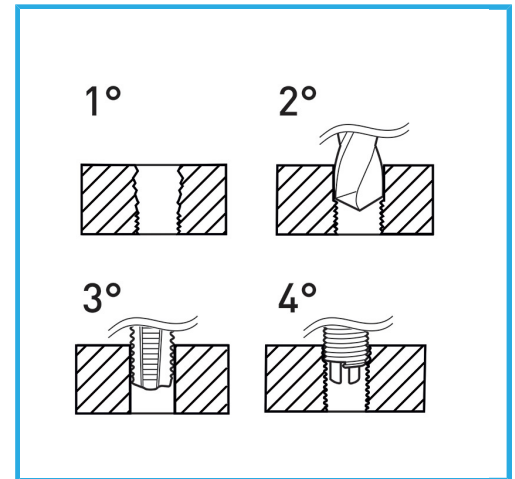

Abmessungen	M 12 x 1.75
Bohrer	Ø 12.4 mm
Gewindebohrer STI	E011/M120X175M
Montagewerkzeug	E011/U15 g
Brechwerkzeug	E011/A15 g
Anzahl der Einsätze	10
Bruttogewicht	0,68 kg
Verpackungsmaße	170x130x40 h mm
EAN-Code	8012667369026



Aufhängbar

HSS



INOX