

GEEIGNET ZUR GEWINDEREGENERATION ODER UM SEHR WIDERSTANDSFÄHIGES GEWINDESCHNEIDEN IN WEICHE MATERIALIEN ZU ERHALTEN.

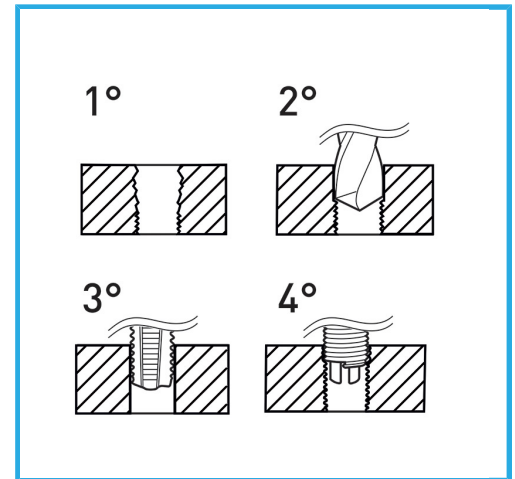

Abmessungen	M 12 x 1.25
Bohrer	Ø 12.3 mm
Gewindebohrer STI	E011/M120X125M
Montagewerkzeug	E011/U15 g
Brechwerkzeug	E011/A15 g
Anzahl der Einsätze	10
Bruttogewicht	0,63 kg
EAN-Code	8012667365271



Aufhängbar

HSS



-