

GEEIGNET ZUR GEWINDEREGENERATION ODER UM SEHR WIDERSTANDSFÄHIGES GEWINDESCHNEIDEN IN WEICHE MATERIALIEN ZU ERHALTEN.

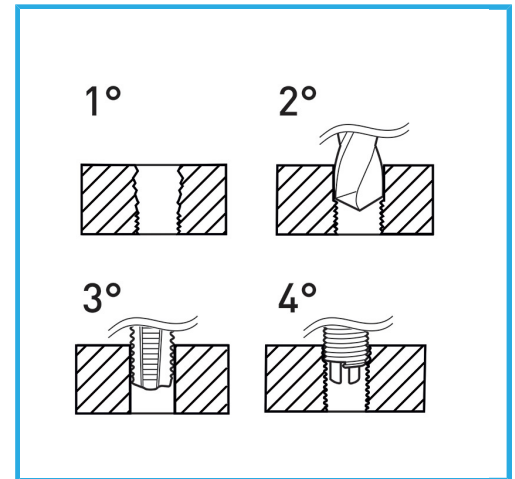

<b>Abmessungen</b>	M 18 x 1.5
<b>Bohrer</b>	-
<b>Gewindebohrer STI</b>	E011/M180X150M
<b>Montagewerkzeug</b>	E011/U20 g
<b>Brechwerkzeug</b>	- g
<b>Anzahl der Einsätze</b>	5
<b>Bruttogewicht</b>	0,71 kg
<b>EAN-Code</b>	8012667362980



Aufhängbar

HSS



INOX