

GEEIGNET ZUR GEWINDEREGENERATION ODER UM SEHR WIDERSTANDSFÄHIGES GEWINDESCHNEIDEN IN WEICHE MATERIALIEN ZU ERHALTEN.

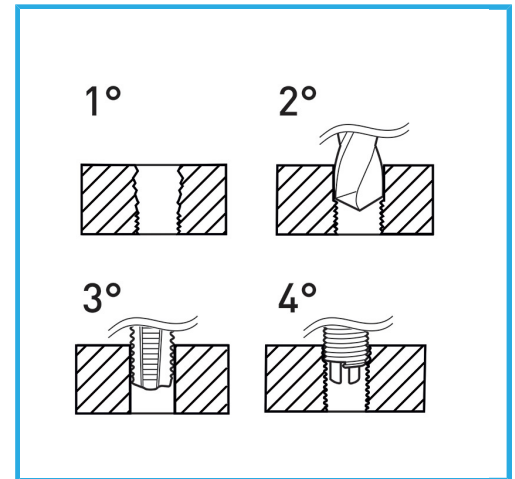

Abmessungen	M 6 x 1.0
Bohrer	Ø 6.3 mm
Gewindebohrer STI	E011/M060X100M
Montagewerkzeug	E011/U09 g
Brechwerkzeug	E011/A09 g
Anzahl der Einsätze	20
Bruttogewicht	0,41 kg
Verpackungsmaße	175x130x40 h mm
EAN-Code	8012667367411



Aufhängbar

HSS



INOX