

GEEIGNET ZUR GEWINDEREGENERATION ODER UM SEHR WIDERSTANDSFÄHIGES GEWINDESCHNEIDEN IN WEICHE MATERIALIEN ZU ERHALTEN.

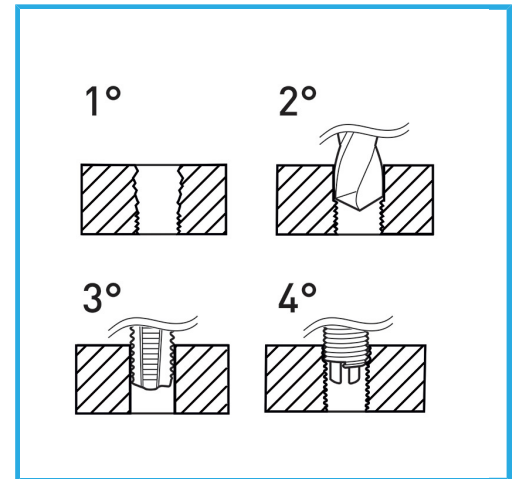

Abmessungen	M 4 x 0.7
Bohrer	Ø 4.2 mm
Gewindebohrer STI	E011/M040X070M
Montagewerkzeug	E011/U06 g
Brechwerkzeug	E011/A06 g
Anzahl der Einsätze	20
Bruttogewicht	0,35 kg
EAN-Code	8012667367589



Aufhängbar

HSS



INOX