

GEEIGNET ZUR GEWINDEREGENERATION ODER UM SEHR WIDERSTANDSFÄHIGES GEWINDESCHNEIDEN IN WEICHE MATERIALIEN ZU ERHALTEN.

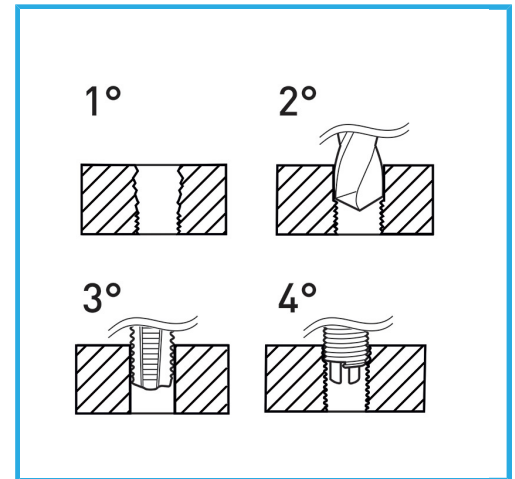

Abmessungen	M 9 x 1.0
Bohrer	Ø 9.3 mm
Gewindebohrer STI	E011/M090X100M
Montagewerkzeug	E011/U12 g
Brechwerkzeug	E011/A12 g
Anzahl der Einsätze	10
Bruttogewicht	0,54 kg
EAN-Code	8012667365189



Aufhängbar

HSS -



INOX -