

GEEIGNET ZUM REGENERIEREN VON SCHRAUBENGWINDEN ODER  
FÜR SEHR STARKES KLOPFEN IN WEICHE MATERIALIEN.

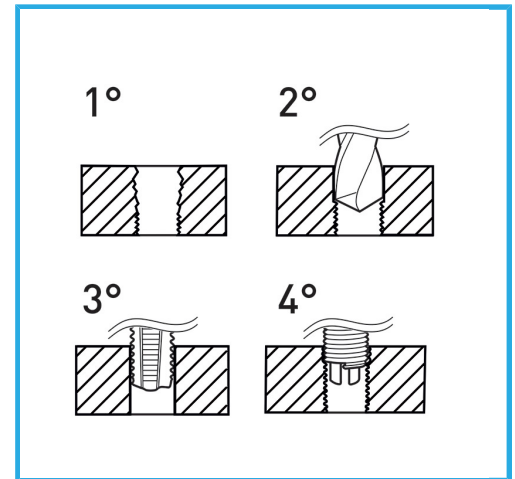

<b>Maße</b>	M6 - M14 mm
<b>Gewindebohrer STI</b>	M6 x 1.0 - M8 x 1.25 - M10 x 1.5 - M12 x 1.75 - M14 x 1.25
<b>Bohrer</b>	6.3 mm - 8.3 mm - 10.4 mm - 12.4 mm
<b>Gewindeeinsätze</b>	M6=25 M8=25 M10=25 M12=10 M14=10
<b>Montagewerkzeug</b>	5 St g
<b>Brechwerkzeug</b>	4 St g
<b>Bruttogewicht</b>	2,66 kg
<b>EAN-Code</b>	8012667367329



Koffer



HSS

-



INOX

-



113 Pcs