

SONDERAUSFÜHRUNG ZUR HERSTELLUNG DES  
GEWINDEEINSATZ-GEHÄUSESITZES.

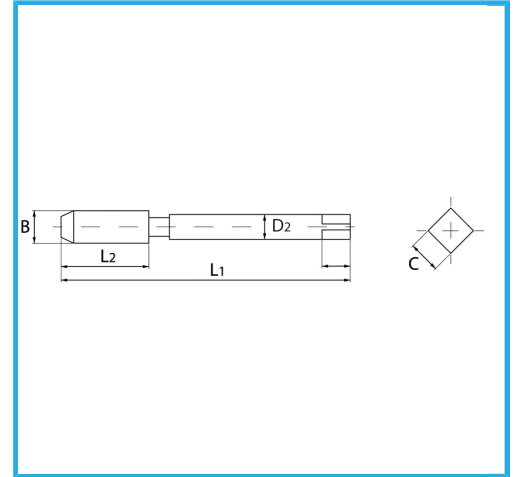

Maß	9/16" x 18
B	16.1 mm
L1	104.0 mm
L2	29.0 mm
D2	12.5 mm
C	10.00 mm
Bruttogewicht	0,09 kg
EAN-Code	8012667366834



Aufhängbar

HSS-G