

SONDERAUSFÜHRUNG ZUR HERSTELLUNG DES  
GEWINDEEINSATZ-GEHÄUSESITZES.

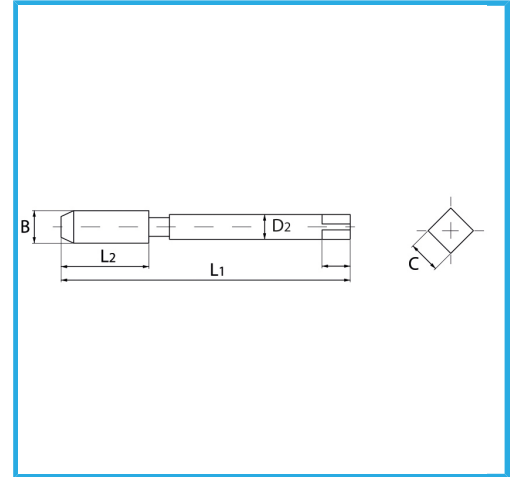

Maß	M 12 x 1.75
B	14.3 mm
L1	95.0 mm
L2	30.0 mm
D2	11.2 mm
C	9.00 mm
Bruttogewicht	0,07 kg
EAN-Code	8012667368401



Box

HSS-G