

SONDERAUSFÜHRUNG ZUR HERSTELLUNG DES
GEWINDEEINSATZ-GEHÄUSESITZES.

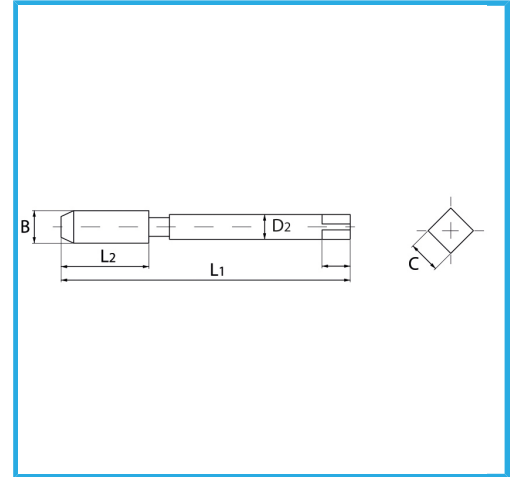

Maß	M 6 x 1.0
B	7.3 mm
L1	72.0 mm
L2	22.0 mm
D2	8.0 mm
C	6.30 mm
Bruttogewicht	0,02 kg
EAN-Code	8012667368272



Box

HSS-G