

**EINSTELLUNG DER
SCHNITTIEFENWINKELVERSTELLUNGSPERRFUNKTIONSTAUBABSAUGSYSTEM
MIT ABGASROHRBEDIENERSCHUTZWEICHER...**

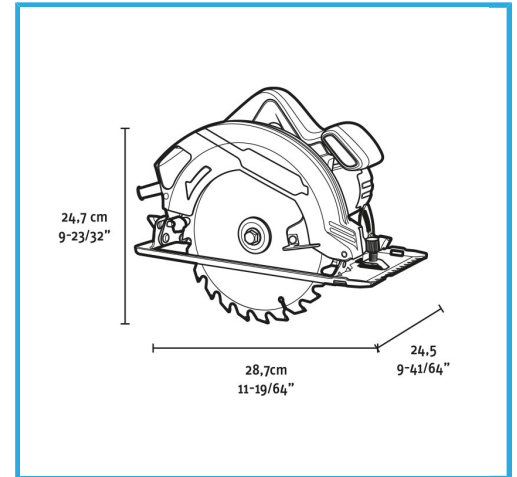

Leistung	1500 W g
Stromstärke bei 220-230 V	6,8 A
Leerlaufdrehzahl	5500 min-1
Min / max Ø Klinge	185 / 190 mm
Lochdurchmesser	20 mm
Klingenstärke	2 mm
Schnitttiefe	Max 66 mm (90°) / 46 mm (45°)
EAN-Code	8012667404536
Bruttogewicht	5,28 kg



Box - Winkelverstellung



Lock-Off - Tiefenverstellung



Staubabsaugung