

KLEMMHEBEL-BEFESTIGUNGSSYSTEM UNTERSCHIEDLICHE
GESCHWINDIGKEITSTAUBABSAUGSYSTEM MIT BEHÄLTER /
KOMPATIBEL MIT...

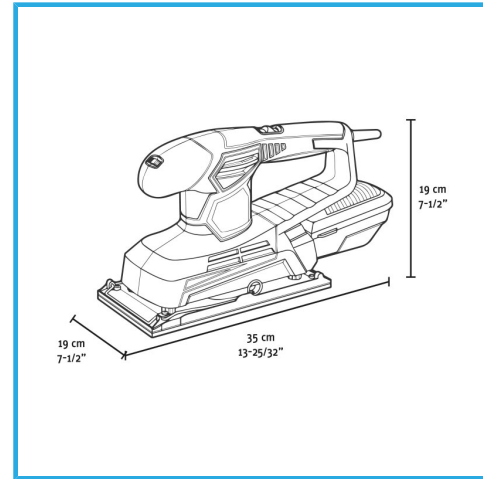

Leistung	350 W g
Stromstärke bei 220-230 V	1,5 A
Leerlaufdrehzahl	6000-11000 min-1
Leerlaufschwingzahl	12000-22000 min-1
Exzentrizität	2,5 mm
Schleifpapiergröße	115 x 280 mm
Schleifflächengröße	115 x 230 mm
EAN-Code	8012667404550
Verpackungsmaße	365 x 125 x 190 h mm
Bruttogewicht	2,76 kg



Box



Weicher
Griff



Gürtelhaken



- Variable
Geschwindigkeit



D-Griff



Staubabsaugu