

MOTORE A MAGNETI PERMANENTI, TELAIO IN METALLO, CAVO RESISTENTE, CON DISPOSITIVO ANTI SVOLGIMENTO DEL CAVO E GUIDA CAVO. DA...

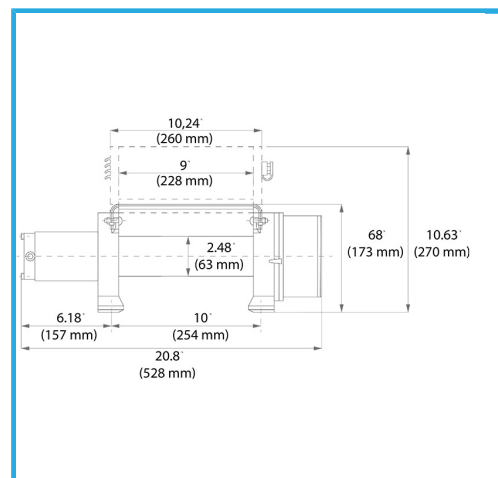

€495,00
~~€1.150,00~~



Tiro nominale orizzontale	2720 kg
Velocità	1,3 - 4,5 m / min
Motore	12 V 1,3 kW 1,8 hp
Riduzione	294:1
Dimensioni cavo	ø 7,2 mm x 32 m
Dimensioni tamburo	ø 63 x 228 mm
Dimensioni ingombro	520 x 180 x 175h mm
Peso netto	29 kg
Peso lordo	32,50 kg
Codice EAN	8012667213619

