

FÜR SCHNELLEN WERKZEUGWECHSEL DANK ARRETIER- /
ENTRIEGLUNGHEBEL. ZUSAMMENSETZUNG DES SETS: - 1
WERKZEUGHALTERREVOLVER - 4..

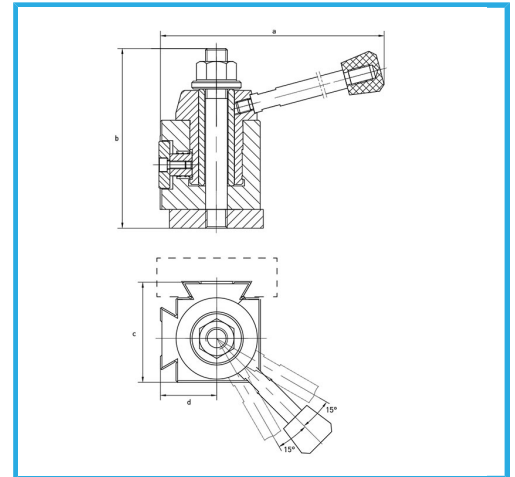

Länge	100 mm
Breite	100 mm
Höhe	92 mm
Bohrung	22,22 mm g
Werkzeughöhe	25 mm
Bruttogewicht	18,24 kg
EAN-Code	8012667213732

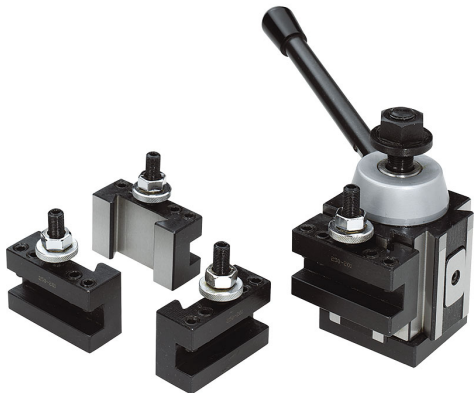

Box