

TO SLIGHTLY CORRECT THE AXIALITY AND DIAMETER OF THE HOLES.
 IT CAN WORK AUTOMATICALLY AND MANUALLY.

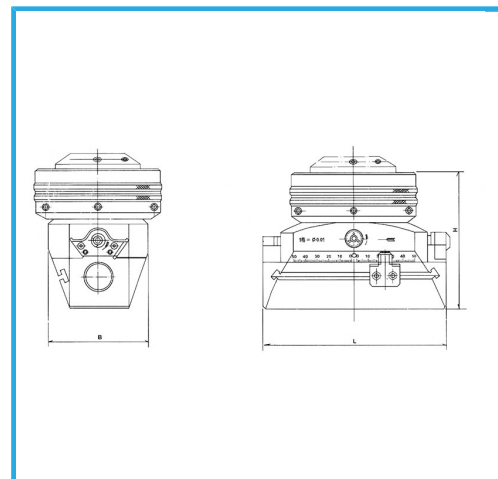

Max facing and boring \varnothing	350 mm
Max stroke of slide	± 25 mm
Fine feed per graduation	0,005 mm
Manual feed per revolution	3 mm
Self acting feed per revolution	0,03-0,06-0,09 0,12-0,15-0,18 mm
\varnothing of tool post holes in head	22 mm
Max \varnothing of head	120 mm
Height of head without shank - (H)	118 mm
Weight of head without shank	6,1 kg
Length of sliding block	105 (L) mm
Width of sliding block	90 (B) mm
Collets hole	8 - 10 - 12 - 14 \varnothing mm
Accessories	1 - 2 - 3 - 4 - 5
Extension hole for tool holder	$\varnothing 10$ mm
Shank	ISO40 - DIN2080
Gross weight	16,00 kg
EAN Code	8012667002916

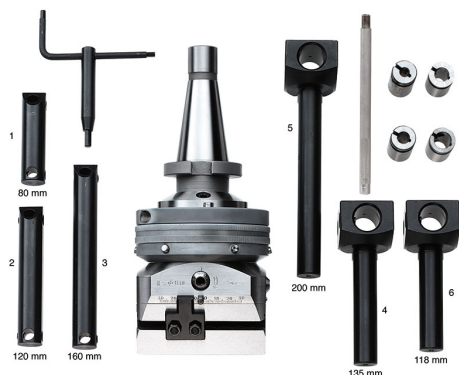

Box

40 Cr



Grounded