

MIT MUFFENANSCHLUSS, EMPFOHLEN FÜR DEN EINSATZ AN MASCHINEN MIT REDUZIERTER LEISTUNG.

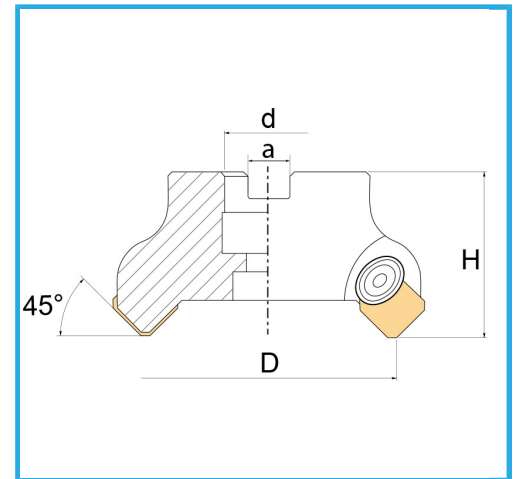

D	100 mm
H	50mm
a	16,4 mm
d	32 mm
Z	6
Schraube	VT00440
Einlegeboden	WSSP
Einsatz (nicht im Lieferumfang enthalten)	SEKN1203...
Bruttogewicht	2,05 kg
EAN-Code	8012667253219

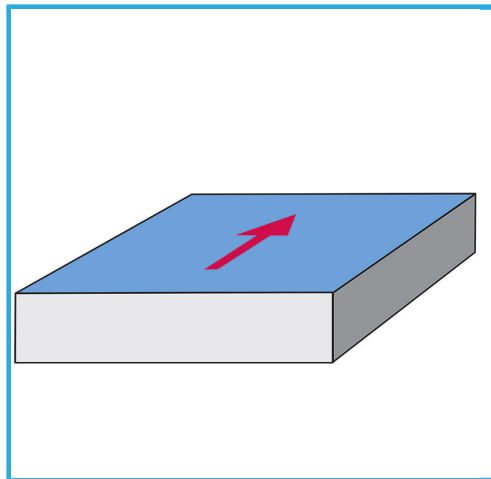

Box



Satiniert



Vernickelt



Extern