

CON CONEXIÓN DE MANGUITO, RECOMENDADO PARA USO EN MÁQUINAS CON POTENCIA REDUCIDA.

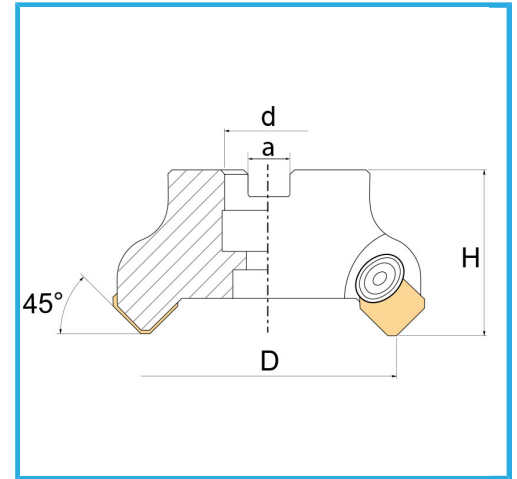

€255,00

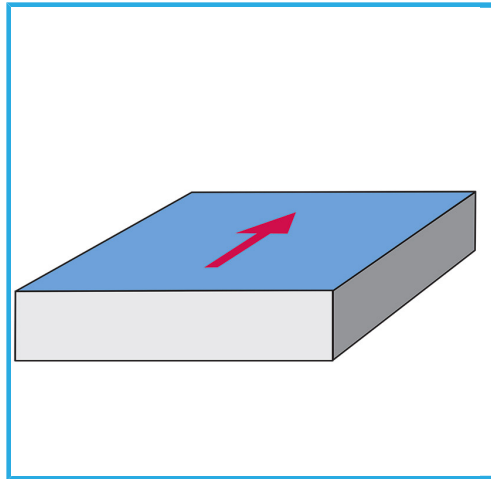

D	100 mm
H	50mm
a	16,4 mm
d	32 mm
Z	6
Tornillo	VT00440
Base de plaquita	WSSP
Plaquita (no incluida)	SEKN1203...
Peso bruto	2,05 kg
Codigo de barras	8012667253219



Caja



Satinado



Niquelada



Externa