

GEEIGNET ZUR GEWINDEREGENERATION ODER UM SEHR WIDERSTANDSFÄHIGES GEWINDESCHNEIDEN IN WEICHE MATERIALIEN ZU ERHALTEN.

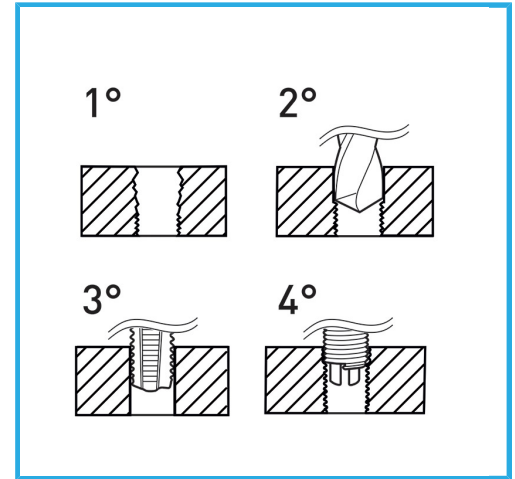

Gewindeinsatz	M10
Bohrer	10,4 mm
Gewindebohrer	x M10
Handgriff	2
Bruttogewicht	0,58 kg
EAN-Code	8012667249960



Aufhängbar

HSS



INOX