

ART. 0855/T15
CHIAVI TORX CON MANICO ANATOMICO IN PLASTICA

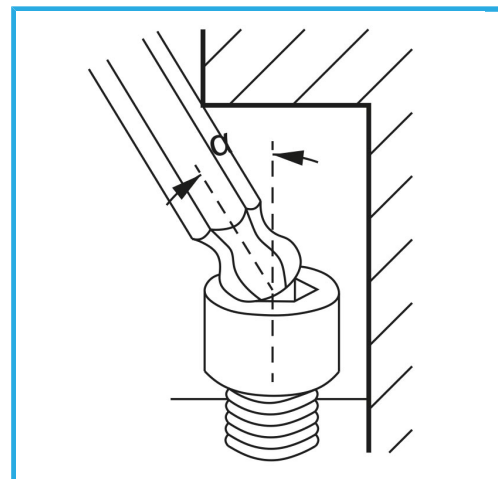

€2,65



Misura	T15
Lunghezza	100 mm
Peso lordo	0,04 kg
Codice EAN	8012667186999



Append.



Cromata



-



Mo-V

-